

SN30-SN31 Series

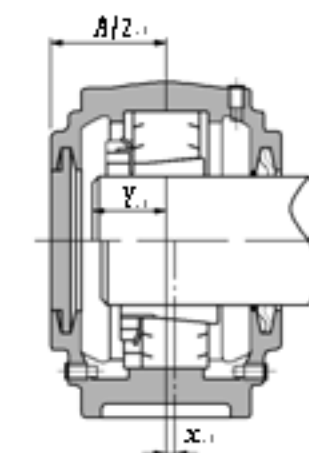
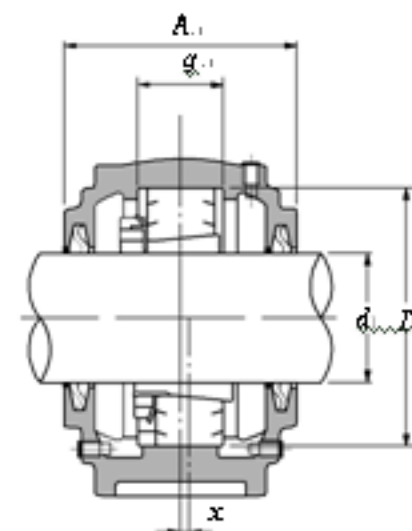
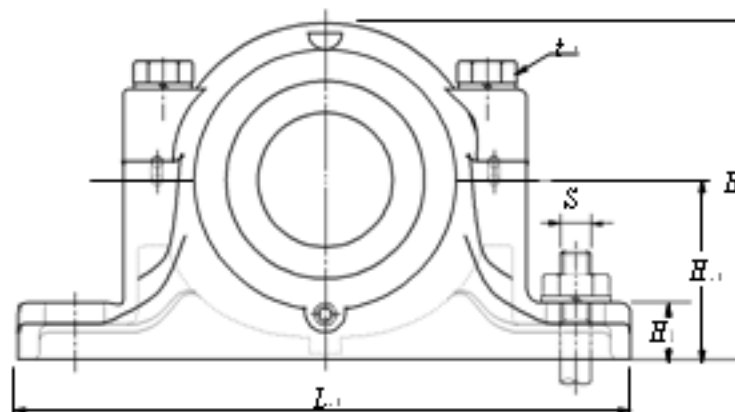
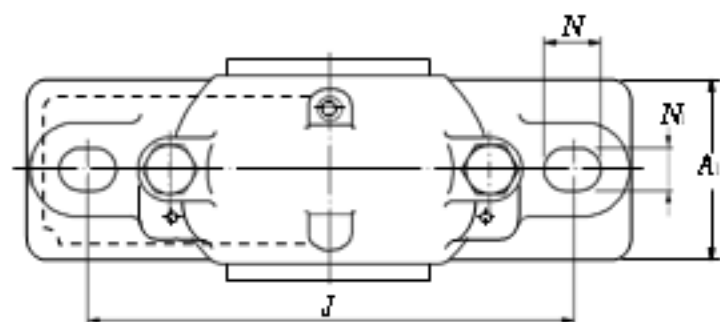

轴径 Shaft dia. mm d1	轴承座 代号 Housing numbers	基本尺寸 Dimensions												大致 Approx. S	重量 Mass kg	公称代号Nominal number.			大致 Approx. mm y	密封 代号 Seal. number
		D	H	J	M1	N	mm. A L		A1	H1	H2	g	t			球面滚子轴承 Spherical roller bearing	定位环 Setting ring Number	数量		
110	SN3024	180	112	320	26	32	150	380	110	40	217	56	M20	M24	17	23024BK;H3024X	SR180X10	1	47	ZF24
115	SN3026	200	125	350	26	32	160	410	120	45	240	62	M20	M24	20	23026BK;H3026	SR200X10	1	51	ZF26
125	SN3028	210	140	350	26	32	170	410	120	45	260	63	M20	M24	25	23028BK;H3028	SR210X10	1	53	ZF28
135	SN3030	225	150	380	28	36	175	445	130	50	283	66	M24	M24	30	23030BK;H3030	SR225X10	1	56	ZF30
140	SN3032	240	150	390	28	36	190	460	130	50	290	70	M24	M24	33	23032BK;H3032	SR240X10	1	61	ZF32
150	SN3034	260	160	450	33	42	200	530	160	60	310	77	M24	M30	46	23034BK;H3034	SR260X10	1	66	ZF34
160	SN3036	280	170	470	33	42	210	550	160	60	330	84	M24	M30	52	23036BK;H3036	SR280X10	1	70	ZF36
170	SN3038	290	170	470	33	42	210	550	160	60	335	85	M24	M30	52	23038BK;H3038	SR290X10	1	72	ZF38
100	SN3122	180	112	320	26	32	155	380	110	40	217	66	M20	M24	18	23122BK;H3122X	SR180X10	1	51	ZF22
110	SN3124	200	125	350	26	32	165	410	120	45	240	72	M20	M24	21	23124BK;H3124X	SR200X10	1	55	ZF24
115	SN3126	210	140	350	26	32	170	410	120	45	260	74	M20	M24	26	23126BK;H3126	SR210X10	1	57	ZF26
125	SN3128	225	150	380	28	36	180	445	130	50	283	78	M24	M24	32	23128BK;H3128	SR225X10	1	60	ZF28
135	SN3130	250	150	420	33	42	200	500	150	50	295	90	M24	M30	40	23130BK;H3130	SR250X10	1	68	ZF30
140	SN3132	270	160	450	33	42	215	530	160	60	315	96	M24	M30	45	23132BK;H3132	SR270X10	1	74	ZF32
150	SN3134	280	170	470	33	42	220	550	160	60	330	98	M24	M30	51	23134BK;H3134	SR280X10	1	76	ZF34
160	SN3136	300	180	520	33	42	230	610	170	70	355	106	M30	M30	63	23136BK;H3136	SR300X10	1	81	ZF36
170	SN3138	320	190	560	33	42	240	650	180	70	375	114	M30	M30	76	23138BK;H3138	SR320X10	1	86	ZF38