

SD30-SD30G Series

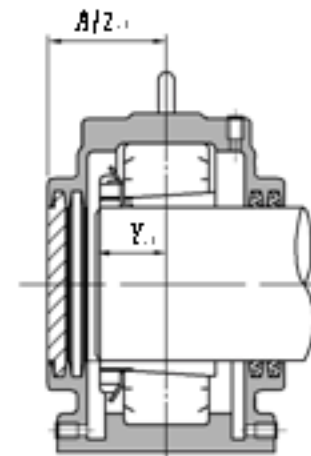
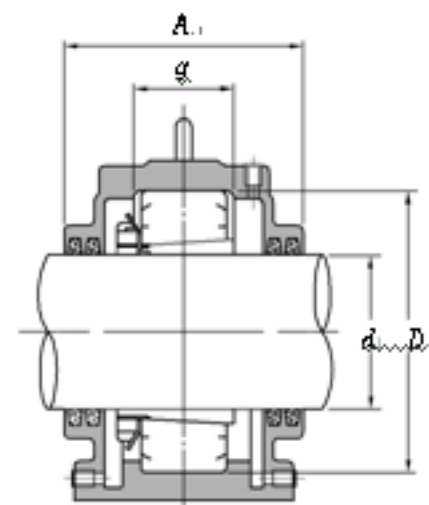
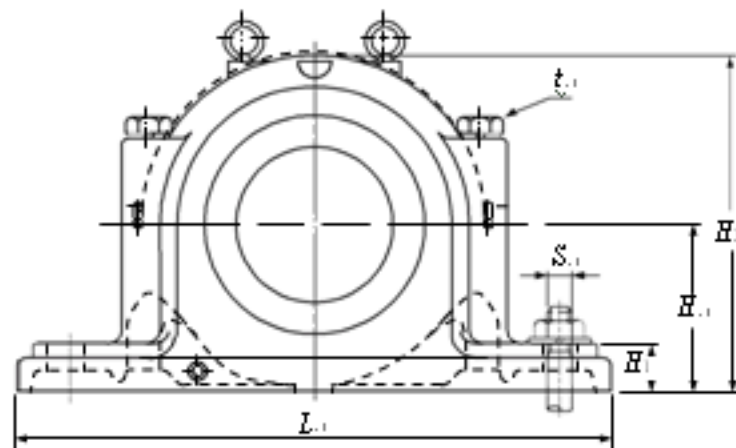
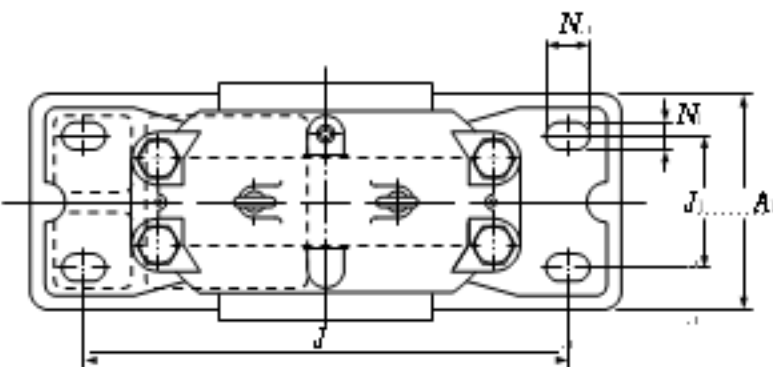

轴径 Shaft dia. mm d	轴承座代号 Housing numbers		基本尺寸Dimensions mm.													大致 Approx. S.	重量 Mass kg	公称代号 Nominal number 球面滚子轴承 Spherical roller bearings	大致 Approx. mm y	密封 代号 Seal number
	自由端 free side	固定端 fixed side	D	H	J	J ₁	N ₁	N	A	L	A ₁	H ₁	H ₂	g	t					
150	SD3034	SD3034G	260	160	450	110	32	42	230	540	200	50	320	77	M24	M30	70	23034BK;H3034	66	ZF34
160	SD3036	SD3036G	280	170	470	120	32	42	250	560	220	50	340	84	M24	M30	80	23036BK;H3036	70	ZF36
170	SD3038	SD3038G	290	170	470	120	32	42	250	560	220	50	345	85	M24	M30	85	23038BK;H3038	72	ZF38
180	SD3040	SD3040G	310	180	510	140	32	52	270	620	250	60	360	92	M24	M30	100	23040BK;H3040	76	ZF40
200	SD3044	SD3044G	340	200	570	160	35	55	290	700	280	65	400	100	M30	M30	130	23044BK;H3044	79	ZF44
220	SD3048	SD3048G	360	210	610	170	35	55	300	740	290	65	420	102	M30	M30	150	23048BK;H3048	84	ZF48
240	SD3052	SD3052G	400	240	680	190	40	60	340	820	320	70	475	114	M30	M36	210	23052BK;H3052	90	ZF52
260	SD3056	SD3056G	420	250	710	200	42	62	350	860	340	85	500	116	M36	M36	240	23056BK;H3056	95	ZF56
280	SD3060	SD3060G	460	280	770	210	42	62	360	920	350	85	550	128	M36	M36	300	23060BK;H3060	10E	ZF60
300	SD3064	SD3064G	480	280	790	210	42	62	380	940	360	85	560	131	M36	M36	320	23064BK;H3064	10E	ZF64
380	SD3080	SD3080G	600	365	960	270	57	77	430	1140	420	120	710	158	M42	M48	620	23080BK;H3080	131	GS80
400	SD3084	SD3084G	620	375	980	270	57	77	430	1160	420	120	735	160	M42	M48	690	23084BK;H3084	132	GS84
410	SD3088	SD3088G	650	390	1040	280	57	77	460	1220	450	125	765	167	M42	M48	800	23088BK;H3088	144	GS88
430	SD3092	SD3092G	680	405	1040	310	57	77	470	1220	460	130	790	173	M42	M48	870	23092BK;H3092	147	GS92
450	SD3096	SD3096G	700	415	1100	320	57	77	485	1270	470	130	820	175	M42	M48	980	23096BK;H3096	14E	GS96